



## INSTALLATION INSTRUCTIONS

Note: The following instructions cover assembly of Moldboard, Sector and A-Frame. Refer to separate instructions for installation of plow mounting and hydraulic system.

- a. Liberally coat Pivot Pins (22) with chassis lubricant.
- b. Attach Sector (29) to Moldboard (1) with Pivot Pins (22) and insert Hair Pin Cotter. Grease Pivot Pins using grease fittings.
- c. Attach Eye Bolts (23) to Moldboard (1) and trip Springs (24) to Sector (29), making certain locknuts (23) are positioned as shown in Figure 1.
- d. Make certain each Eye Bolt (23) is in a vertical position as shown in figure 1 so that the Eye Bolt (23) and Trip Spring (24) hinge properly when moldboard trips.

Note: Proper tension is attained when Trip Spring (24) coils just begin to separate and then tightening top locknut four additional turns.

- e. Attach A-Frame to Sector (29) as shown in Figure 2. **IMPORTANT:** Install King Bolt (25) from bottom so that locknut (25) is on top.

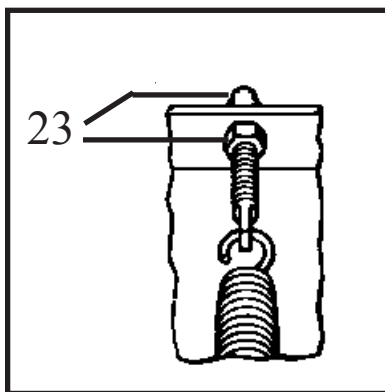

Figure 1

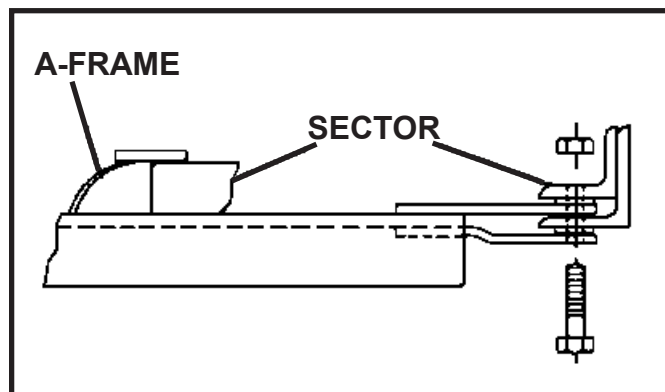

Figure 2